



# PGP™ 20

## OPERATING GUIDE

**CAUTION**  
**TO PREVENT ELECTRICAL SHOCK, DO NOT EXPOSE THIS INSTRUMENT TO RAIN OR MOISTURE.**  
**BEFORE USING THIS INSTRUMENT, READ BACK COVER FOR FURTHER WARNINGS.**

### CLASS B COMPUTING DEVICE: INFORMATION TO USER

This equipment generates and uses radio frequency energy and if not installed and used properly, that is, in accordance with the manufacturer's instructions, may cause interference to radio and television reception. It has been type tested and found to comply with the limits for a Class B computing device in accordance with the specifications in Subpart J of Part 15 of FCC Rules, which are designed to provide reasonable protection against such interference in a residential installation. However, there is no guarantee that interference will not occur in a particular installation. If this equipment does cause interference to radio or television reception, which can be determined by turning the equipment off and on, the user is encouraged to try to correct the interference by one or more of the following measures:

- reorient the receiving antenna
- relocate the equipment with respect to the receiver
- move the equipment away from the receiver
- plug the equipment into a different outlet so that the equipment and receiver are on different branch circuits.

If necessary, the user should consult the dealer or an experienced radio-television technician for additional suggestions. The user may find the following booklet prepared by the Federal Communications Commission helpful:

*"How to Identify and Resolve Radio-TV Interference Problems"*

This booklet is available from the U.S. Government Printing Office, Washington, DC 20402, Stock No. 004-000-00345-4.

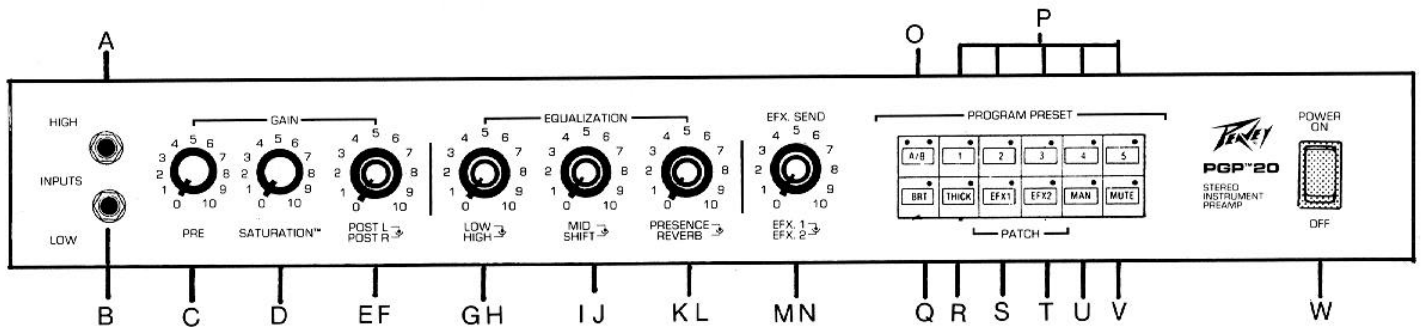
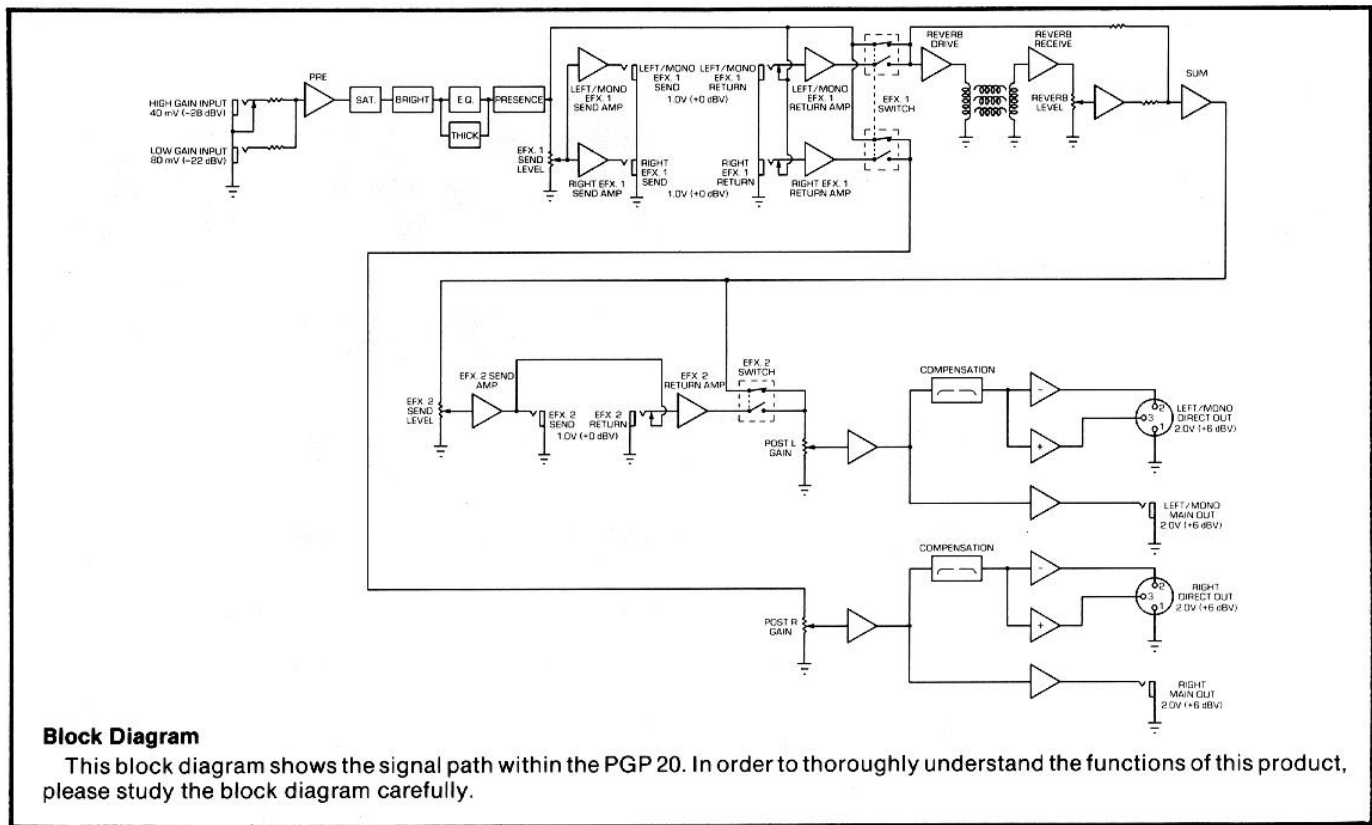
### General Description

The PGP™ 20 is a rack-mountable MIDI-compatible musical instrument control preamplifier which represents a state-of-the-art unification of advanced digital and analog design technologies. In the PGP 20, the intelligence of microprocessor control combines with the precision of digitally-controlled analog signal processing to provide the performer with the ultimate in both tonality and convenience. The PGP 20 is configured in such a manner that any combination of control settings may be stored within the unit's internal memory, to be recalled at the player's discretion. Recall of stored programs may also be accomplished remotely by means of any Peavey remote MIDI controller, or by a number of other available devices.

The PGP 20 incorporates many of the features found on other professional Peavey musical instrument amplifiers. The unique Gain Block circuitry incorporates the patented Peavey Saturation™ circuit, allowing the player total command of the system's distortion and compression characteristics. A full range of equalization controls, including mid shift and active presence circuits, provide complete control over system tonality. The proven full-range spring reverb system utilizes current source drive for maximum damping and performance.

Within the PGP 20, particular attention has been given to the increased demand for advanced signal processing capability. Two fully programmable effects loops have been incorporated into the unit, allowing such capabilities as pre- or post-reverb effects insertion and single-source stereo output/throughput and mixing capability.

The PGP 20 offers performance capability previously unattainable in an instrument control preamplifier. In order to achieve maximum performance from this product, it is necessary to fully understand the function of each control. Please read this operating guide carefully and completely, and keep it available for future reference.



**Input Jacks (A,B)**

The PGP 20 is equipped with two input jacks which differ in sensitivity and impedance. The High Gain Input (A) is considerably more sensitive than the Low Gain Input (B), and is the input normally used with most instruments, especially when maximum distortion and overdrive are desired. The Low Gain Input exhibits approximately 6dB less input gain, and is intended primarily for use with instruments which have extremely high output signals. High-level signals can prematurely overload the High Gain Input, causing an unpleasant tonality and harsh overdrive characteristics. Experiment with both input jacks to determine which will best suit your individual playing style and your instrument's output characteristics.

**Gain Block (C,D,E,F)**

The PGP 20 has been designed using the unique Peavey Gain Block Circuitry. The Pre Gain, Saturation, and Post Gain Controls operate interdependently to create a full spectrum of sound, from crisp clean response to fully overdriven distortion. Experimentation will be required to determine the relative levels of these controls necessary to produce the most pleasing tonalities.

The functions of all Gain Block controls are programmable, and may be stored as a part of any program.

**Pre Gain Control (C)**

The Pre Gain Control is similar to a conventional volume control in that it is the first level-setting device in the system. Rotating the Pre Gain Control clockwise increases the gain of the preamplifier, thereby raising the volume level of the system.

## **Saturation Control (D)**

The Saturation Control is used to set the operating level of the patented Saturation circuit. Saturation is a highly sophisticated circuit which simulates the gain compression and rich harmonic overload of vacuum tubes. Turning the Saturation control clockwise will increase the effect of the Saturation circuit upon the system's sound.

It must again be noted that all Gain Block controls interact. When using Saturation, the Pre Gain Control (C) must be set to a level sufficient to adequately drive the Saturation circuit. Since increasing the Pre Gain level will cause the system's volume level to increase, the Post Gain Controls (E,F) will also require adjustment to control relative volume levels.

## **Post Gain Controls (E,F)**

Within the PGP 20, the operation of the Post Gain Controls differs somewhat from the traditional role of overall volume control for the system. Due to the multiprogram characteristics of the PGP 20, the Post Gain Controls are best used to regulate the relative volume level of each individual program, as referenced to other programs stored in memory. Rotating the appropriate Post Gain Control clockwise will increase the overall volume of the system, but this increase will only occur within the parameters of any single program; this adjustment will not alter the volume level of any other stored program. If it is desired to simultaneously alter the level of all stored programs, adjustments should be made at the input sensitivity level controls of the system's power amplifiers.

Adjustments to the Post Left Gain Control will affect signal levels at the Left/Mono Main Output Jack (FF) and the Left/Mono Direct Out Jack (DD). Adjustments to the Post Right Gain Control will affect signal levels at the Right Main Out Jack (GG) and the Right Direct Out Jack (EE).

The need for experimentation and comparison to determine the optimum control positions within the Gain Block cannot be overemphasized, either for establishing a new program or for "fine-tuning" existing programs.

## **Equalization Controls**

The PGP 20 features four bands of equalization which provide virtually unlimited tonal control. The Low, Mid, and High EQ bands are the passive type preferred by many guitarists, while the Presence EQ band is active.

The functions of all equalization controls are programmable, and may be stored as a part of any program.

### **Low EQ Control (G)**

The Low EQ Control adjusts the tonality for the amount of smoothness and offers extended bandwidth within the lower frequencies of the tonal range. Care should be taken not to overboost with this control to avoid loss of headroom in other system components. Extreme overboosting of low bass frequencies tends to detract from the projection capability of an amplification system, and may reduce the clarity of complex passages such as lead guitar lines.

### **High EQ Control (H)**

The High EQ Control varies treble frequencies between the midrange and presence frequency bands. Turning this control clockwise will increase the amount of treble in the overall tonal spectrum.

Excessive high frequency equalization can adversely affect the system's tonality if a smooth distorted sound is desired. When working with programs containing significant amounts of Saturation, High EQ settings should be reduced to avoid stridency or harshness in the overall tone.

### **Mid EQ Control (I)**

The Mid EQ Control adjusts the tonality in the vital midrange frequencies. Rotating the Mid EQ Control clockwise increases the midrange for a greater degree of "fat" tonalities. The mid EQ Control operates in conjunction with the Mid Shift Control (J) described below.

### **Mid Shift Control (J)**

The Mid Shift Control determines the frequency at which the Mid EQ Control (I) operates. It is therefore necessary that these two controls be adjusted relative to each other to achieve optimum tonal balance. In operation, the Mid Shift Control will determine *where* the midrange is affected, while the Mid EQ Control will determine *how much* equalization is utilized. Generally little or no midrange equalization is used when bright, clean tones are desired. However, guitarists desiring thicker, fatter tonalities will greatly benefit from more midrange equalization.

### **Presence EQ Control (K)**

The Presence EQ Control offers both cut and boost capability, and regulates the uppermost range of equalization. Within the PGP 20, the Presence circuit is the final stage of equalization and is most useful for determining the final "edge" of the desired sound.

The "flat" (no boost, no cut) setting of the Presence EQ Control is achieved with the control at the twelve o'clock position, with the pointer set at panel marking "5". Control settings counterclockwise from this position will cut high frequencies. Settings clockwise from this position will boost high frequencies.

### **Reverb Control (L)**

The Reverb Control determines the amount of delayed signal returned into the main signal from the internal reverberation system. This internal reverb system is of the spring type preferred by many guitarists. Clockwise rotation of the reverb control increases the amount of reverb effect in the signal.

Inspection of the block diagram on page 2 of this manual will show the location of the reverb system within the signal path. Without external cross-channel patching, the reverb system will only affect signals in the Left/Mono channel. A more complete description of routing reverb-processed signals will be found in the Effects Routing section elsewhere in this manual.

### **Effects Send Level Controls (M,N)**

These controls regulate the signal levels which appear at the various Effects Send Jacks on the rear panel. It is important to note, however, that these controls do not perform identical functions within their respective circuits. A thorough understanding of the independent functions of these controls will allow optimum utilization of the PGP 20, and can aid in preventing inadvertent operational problems.

Both Effects Send Level Controls will always regulate the signal levels appearing at the respective Effects Send Jacks. Enabling or disabling either Effects Loop (via the appropriate EFX Key) does not affect the operation of either control. This will be true for any possible effects routing configuration.

Enabling either Effects Loop enables the PGP 20 to accept signals through the various Effects Return Jacks. Enabling Effects Loop 1 can cause no signal losses, even if no device is connected within any configuration of the loop. However, due to differences in the internal switching characteristics of the two loops, enabling Effects Loop 2 will allow the Effects 2 Send Level Control to influence all post-reverb signals in the Left/Mono channel, even when no device is connected within the loop. In this instance, the Effects 2 Send Level Control will function as a programmable master level control within each program. It is therefore essential, when no device is connected to the Effects 2 Return Jack, to ensure that Effects Loop 2 is disabled within all appropriate programs.

### **Program Control Key Matrix**

The Program Control Key Matrix is an array of twelve pushbutton switches which are used to store, recall, or modify programs within the PGP 20. The upper row of six switches includes the Bank Select Key and the five Program Keys, which perform program storage and recall functions. The lower row of six switches control programmable preset equalization curves (Bright and Thick), access to the external Effects Loops, and the nonprogrammable Manual override and Mute functions.

Information regarding program recall, editing, and program storage will be found elsewhere in this manual. See the section titled "The Programmable System" for further information.

### **A/B (Bank) Select Key (O)**

The program storage capability of the PGP 20 is arranged in two sets, each containing ten programs. Each set of ten programs consists of two banks (A and B) of five programs each. A total of four banks are therefore available, containing a total of twenty programs.

Any bank may be selected by pressing the Bank Select Key. Within either set of ten programs, a quick "press and release" of the Bank Select Key will allow the user to alternate between the two banks in that set.

"Pairing" of banks within sets is indicated by the illumination of the LEDs on the Bank Select Key. Within each set, banks are indicated by the following LED displays:

Set 1	Set 2
Both Off/Green Only	Yellow Only/Both On

Selection between sets of programs may also be accomplished by the Bank Select Key. Since the PGP 20 will always be operating within one of the two sets, pressing and holding the Bank Select Key will select the other set. This selection will be indicated by the LEDs on the key, which will change to indicate the alternate set within two seconds after the key is pressed. Entry into a set occurs through Bank A of the set.

### **Program Keys 1 through 5 (P)**

The five Program Keys serve to recall or store programs in memory.

To recall any stored program within a set, first select the correct bank by pressing the Bank Select Key (O) until the desired LED display is illuminated. Then press and quickly release the appropriate Program Key. A small LED on the Program Key will illuminate to show which program has been selected.

To store a program, select the desired bank, then press and hold the desired Program Key until the LED on the key stops flashing. The program is now stored in the desired location.

If a program has been selected, but not modified, the LED on the Program Key will remain constantly illuminated. As soon as the PGP 20 detects a change in a selected program, the LED on the Program Key will begin to flash off-and-on. This flashing LED serves as a reminder that a program has been edited (modified). An edited program may be stored in any location as previously described.

### **BRT Key (Q)**

The BRT (Bright) Key adds a preset high frequency equalization boost to the sound of the system. An LED on the key will illuminate when this key is pressed, or when this parameter is being utilized within a program. Functions of the High EQ Control (H) and the Presence Control (K) may be somewhat reduced when the Bright circuit is in use.

The Bright function is a programmable parameter, and may be stored as a part of any program.

### **Thick Key (R)**

The Thick Key adds a preset mid-band equalization boost, and is commonly used with high level Saturation control (D) settings. When the Thick function is activated, high frequencies may appear to be less pronounced due to the "fullness" added by the boosted midrange frequencies. In addition, normal functions of the Low EQ Control (G) and Mid EQ Control (I) may be somewhat reduced when the Thick function is in use.

The Thick function is a programmable parameter, and may be stored as a part of any program.

### **EFX 1 Key (S)**

The EFX 1 (Effects Loop 1) Key adds a stereo-capable post-EQ effects loop into the circuit. A small LED on the key will illuminate to indicate that the loop has been enabled. For a complete discussion of the capabilities of this loop, see the section titled "Effects Routing" in this manual.

Enabling Effects Loop 1 allows the PGP 20 to accept signals at either of the Effects 1 Return Jacks (Z, AA) on the rear panel. The enable/disable function is a programmable parameter, and may be stored as a part of any program.

### **EFX 2 Key (T)**

The EFX 2 (Effects Loop 2) Key adds a single-channel post-EQ post-reverb effects loop into the circuit. A small LED on the key will illuminate to indicate that the loop has been enabled.

Enabling Effects Loop 2 allows signals to be received at the Effects 2 Return Jack (CC) on the rear panel. The enable/disable function is a programmable parameter, and may be stored as a part of any program.

Enabling Effects Loop 2 may also cause the Effects 2 Send Level Control to function in an unconventional manner. See the control description (N) for further details.

### **MAN Key (U)**

The MAN (Manual) Key provides a means of "overriding" the programmed functions of the PGP 20. When the MAN Key is depressed, all controls return to their manual (actual settings) position, and any program presently in use is overridden. A small LED on the key will illuminate to indicate that the manual function has been selected. The unit will remain in manual mode until the current manual program is stored in memory, or until a stored program is recalled from memory.

It is not necessary to place the PGP 20 in manual mode in order to alter control settings. All controls are accessible at any time, and changing the setting of any control will cause that control to override its programmed setting. The MAN Key is simply a way to gain access to all controls immediately, without alteration of any existing program.

The Manual function is not a programmable parameter.

#### **Mute Key (V)**

The Mute Key is used to temporarily silence the amplifier without modifying any sound or system setting. The Mute function may be used to place the system in "stand-by" mode during editing or performance. For obvious reasons, the Mute function is not a programmable parameter.

#### **Power On/Off Switch (W)**

The Power On/Off Switch is a simple two-position switch which supplies AC power to the PGP 20.

### **The Programmable System**

The PGP 20 is equipped with complete storage, recall, and editing capability. In order to achieve optimum performance from the system, it is necessary to fully understand these programming functions.

The PGP 20 contains twenty storage locations, each of which may contain one program. A program is simply a combination of control settings, which comprise one particular "sound". When a program is stored, a digital value is assigned to the relative position of each control; it is these digital values that are "remembered" by the internal memory circuits. Program information includes values for all controls except the MAN and Mute keys and, on export models, the Voltage Selector Switch. When a program is recalled, the digital information corresponding to that program will determine the relative function of each control, regardless of the physical position of the control itself.

#### **Program Recall**

The twenty program locations are arranged in two sets of ten. Each set consists of two banks, each containing five program locations.

To recall any program, first select the correct bank by means of the Bank Select Key (O) as described in the functional description section. Then press and release the appropriate Program Key (P). This action will automatically recall any desired program. The PGP 20 will now perform in accordance with the information stored within that program, regardless of the physical setting of the unit's controls. Any program may be recalled by this procedure: selection of the appropriate bank and program location.

When recalling another program within the same bank, it is not necessary to reselect the bank. Simply pressing the appropriate program key will select the desired program.

#### **Editing (Program Modification)**

Any stored program may be edited simply by altering the physical position of the appropriate controls. The physical position of a control will have no effect upon a recalled program, *until that control's position is altered*. Whenever the PGP 20 senses that a control is being adjusted, the new position of the control will automatically override the stored program information *for that control only*. For example, suppose that a bit more Saturation is desired within a particular program. Simply increase the setting of the Saturation Control until the desired setting is achieved. The program has now been edited, and is ready for storage or further editing.

When a program is being edited, only those controls which have been physically adjusted will change in value; if a control's position has not been altered, the programmed values for that control will remain unchanged.

Whenever a program is edited in any way, the LED indicator of the appropriate Program Key will begin to flash on and off. This flashing LED provides a visual signal, indicating that editing is in progress. An edited program may be stored in the same location by pressing and holding the Program Key until the LED stops flashing. An edited program may also be "cancelled" by pressing and quickly releasing the Program Key: This action will return the program to its original stored condition.

#### **Program Creation**

A program may be created "from scratch" by adjusting the unit's controls to the desired positions. To create such a program, press the MAN Key (U) to place the PGP 20 in manual mode. In manual mode, all controls will operate at their indicated values and adjustment of any control or controls will create a new program. When the new program is satisfactorily adjusted, it may be stored in any location.

#### **Program Storage**

Any program--new, edited, or existing--may be stored within any location. To store a newly created or edited program, first decide which bank and program locations will be used. Select the desired bank via the Bank Select Key (O). Then press the desired Program Key (P) and hold it in until the LED stops flashing (about three seconds). The program is now stored in the selected location.

To move an existing program to a new location, the program must first be recalled, then it may be stored in the new location as described above. It should be noted that any program so moved will now exist in both the old and the new locations.

It should also be noted that storing a program into any location will erase any information previously stored in that location. Care should be taken to insure that a valuable program is not inadvertently lost by careless program storage.

#### **Factory Programs/Program Deletion**

The PGP 20 is supplied with twenty programs in place, which were input by factory technicians during manufacture of the unit. These programs consist of two identical sets of ten programs each.

Capability is provided to simultaneously delete all user-input programs from memory. When this is done, the PGP 20 will automatically revert to the original factory programs. *Note: this procedure will cause destruction of all user-input information.*

The following procedure will clear all user-input memory:

1. Turn the PGP 20 off.
2. Press and hold the Bank (A/B) Select Key (O) and the Mute Key (V).
3. While holding both keys in position, turn the PGP 20 on.

Generally, it is not possible to clear user-input information from a single memory location, and to restore the factory program for that location only. However, it is possible to replace a user-input program with the original factory program provided that the original program still exists, unaltered, in another memory location. The input configuration of the factory programs (two identical sets of ten) makes this possible.

For example, suppose that it is desired to replace the user-input contents of Set 1, Bank B, Program 1 with the original factory program for that location. This will be possible only if the unedited factory program still exists in Set 2, Bank B, Program 1 or another location. If this is the case, reinsertion of the factory program may be accomplished as follows:

1. Recall the desired program (Set 2, Bank B, Program 1) in the normal manner. When this is achieved, both LED indicators on the Bank Select Key will be illuminated, as will the LED on Program Key 1.
2. Press and hold the Bank Select Key. Within two seconds, the LEDs on the key will cycle to "both off", indicating that programs in Set 1 are now accessible. Release the Bank Select Key.
3. Select Bank B by a quick press-and release of the Bank Select Key. The green LED on the key should now be illuminated.
4. Press and hold Program Key 1 until the LED on the key stops flashing.

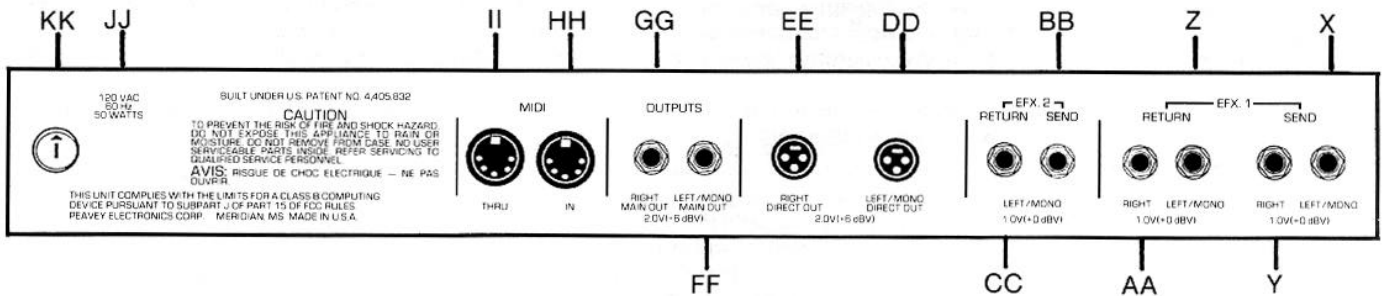
What has been described is the procedure for storing a particular program in another location. In this example, an unaltered factory program was reinserted into its duplicate location, replacing the existing program in that location.

### Program Retention

The PGP 20 contains a special rechargeable internal battery to protect and maintain stored programs while the unit is not in use. When the unit is in use (power on), an internal circuit automatically recharges the internal battery. During periods when the PGP 20 is not in use, user-input programs will be retained in memory for approximately four weeks. Factory-input programs will be retained indefinitely.

If the PGP 20 is turned off for a prolonged period of time (four weeks or longer), all user-input programs may be lost from memory. If this occurs, all programs will automatically revert to the original factory-input programs. It is recommended, therefore, that all user-input programs be recorded in writing in case the need for reprogramming arises.

Under conditions of normal use, the internal battery should have a life expectancy in excess of five years. Battery failure is indicated if the PGP 20 refuses to retain user-input programs during a power-on/power off cycle. Since the battery is an integral circuit component, replacement of the battery should be performed only by an Authorized Peavey Dealer or qualified service technician.



### REAR PANEL FEATURES

#### Left/Mono Effects 1 Send Jack (X)

#### Right Effects 1 Send Jack (Y)

These 1/4" jacks supply signals for effects routing purposes. Signals which appear at these jacks are post-EQ, and are line level. Signal levels at these jacks are controlled by the Effects 1 Send Level Control (M) on the front panel. Identical signals appear at both jacks under all circumstances.

#### Left/Mono Effects 1 Return Jack (Z)

This 1/4" jack accepts line level signals into the Left/Mono channel. Signals routed to this jack will reenter the PGP 20 pre-reverb and pre-Effects Loop 2, and may be further processed within either of these circuits.

Effects Loop 1 must be enabled, via the EFX 1 Key (S) on the front panel, to allow signals to enter the unit through this jack.

#### Right Effects 1 Return Jack (AA)

This 1/4" jack accepts line level signals into the right channel. Signals inserted through this jack are not processed by the reverb circuit, nor are they routed to Effects Loop 2. These signals pass directly to the Right Post Gain Control (F), and to the Right Main Output (GG) and the Right Direct Output (EE).

Effects Loop 1 must be enabled, via the EFX 1 Key (S) on the front panel, to allow signals to enter the unit through this jack.

#### Effects 2 Send Jack (BB)

This 1/4" jack supplies signals from the left/mono channel for effects routing purposes. Signals which appear at this jack are post-EQ, post-Effects Loop 1, post-reverb, and are line level.

Signal levels at this jack are regulated by the Effects 2 Send Level Control (N) on the front panel.

#### Effects 2 Return Jack (CC)

This 1/4" jack accepts signals into the left/mono channel. Signals inserted through this jack are routed directly to the Left/Mono Post Gain Control (E).

Effects Loop 2 must be enabled, via the EFX 2 Key (T) on the front panel, to allow signals to enter the unit through this jack.

**Left/Mono Direct Out (DD)****Right Direct Out (EE)**

These XLR connectors supply balanced line-level signals for direct connection to a mixing or recording console. Signals which appear at these jacks are frequency-compensated to simulate the response characteristics of musical instrument loudspeakers. Therefore, these jacks should only be used to route signals to recording or sound reinforcement equipment.

Signal levels at these jacks are controlled by the Left and Right Post Gain Controls (E,F) on the front panel. Within each jack, pin 1 is ground, pin 3 is hot.

**Left/Mono Main Out (FF)****Right Main Out (GG)**

These ¼" jacks supply unbalanced line-level signals for connection to power amplifiers or other line-level-capable devices. Signals which appear at these jacks are not frequency-compensated (as occurs at the direct outputs) and may be routed to musical instrument loudspeakers following further amplification.

Signal levels at these jacks are controlled by the Left and Right Post Gain Controls (E, F) on the front panel.

**MIDI In Socket (HH)**

The MIDI In Socket is a standard DIN connector which allows for a MIDI controller interface to the PGP 20. When such an interface is established, stored programs may be recalled remotely by means of a Peavey Remote MIDI Controller or other device.

The PGP 20 is a MIDI slave device only. The internal microprocessor can receive information on MIDI Channel 1 only, and will select programs stored within either set in response to commands MIDI Preset Select 1 through MIDI Preset Select 10. Any other codes will be ignored by the internal processor.

Since the PGP 20 responds to only ten Preset Select commands, selection of program sets must be established manually, via the Bank Select Key (O) on the front panel. Within each program set, all ten available programs may be accessed by MIDI command.

**MIDI Through Socket (II)**

This auxiliary MIDI outlet is provided to allow chaining of MIDI-compatible devices without the need for Y-type cables or connectors. Any and all control signals received at the MIDI In Socket (HH) will be routed unaltered to the MIDI Through Socket.

**AC Line Cord (JJ)**

For your safety, the PGP 20 is equipped with a three-wire AC (mains) cable with proper grounding facilities. Do not remove the ground pin under any circumstances. If it is necessary to operate the unit without proper grounding facilities, a suitable grounding adaptor should be used where permitted. Shock hazard and system noise are greatly reduced when the unit is operated with properly grounded receptacles.

**Voltage Selector Switch (KK)**

Export models of this product are equipped with a 220/240 VAC selector switch. To prevent possible unsatisfactory performance or damage to the unit, the correct voltage should be preselected before operating the unit.

**Effects Signal Routing**

Within the PGP 20, inclusion of two independent effects loops, plus the internal spring reverberation system, provide a wide range of effects routing possibilities, several of which are outlined below. In order to thoroughly understand the many possible configurations for signal routing, frequent referral should be made to the signal block diagram on page 2 of this manual.

The PGP 20 allows multiple effects routing in series, in single-source "stereo output" configuration, with or without reverberation, or in several possible combinations of these configurations. The following discussion will begin with simple "patches", and will progress to more complex routings.

Due to the diversity of available effects devices, a complete discussion of the types of processing which may be accomplished is beyond the scope of this manual. However, it must be noted that all Effects Send Jacks on the PGP 20 are capable of line-level voltages (1V RMS, 0 dBV), and that such levels will frequently be present, particularly within programs containing significant amounts of the Saturation effect. Accordingly, system performance will be impaired if the selected external devices are incapable of accepting line-level signals. If instrument-level devices are to be used, it is recommended that they be interconnected between the instrument and the inputs of the PGP 20.

**Operational Cautionary Notes**

In most cases, several possible points exist for patching an effects device into the signal path. Experimentation with these configurations will demonstrate the differences between (and the variations among) the possible patches which can be established. However, certain patches exist which, although not hazardous, may result in unsatisfactory performance. The following operational cautions outline these conditions:

Caution: No connection should be made between any Main Out Jack (FF, GG) and any Effects Return Jack (Z, AA, CC) or Input Jack (A, B) as uncontrollable feedback may result.

Caution: No connection should be made between the Effects 2 Send Jack (BB) and the Left/Mono Effects 1 Return Jack (Z) as uncontrollable internal feedback may occur within the reverberation system.

Caution: No connection should be made between any Effect Send Jack (X, Y, BB) and either front-panel Input Jack (A, B).

**Monaural (Series) Effects Routing**

Monaural effects routing is easily accomplished within either of the two effects loops. If only a single effects device is to be used, the device may be patched either pre-reverb, within Effects Loop 1, or post-reverb, within Effects Loop 2. Experimentation with each loop will determine which patch point produces the most pleasing effects.

In such a configuration, simply connect the appropriate Effects Send Jack (X or BB) to the input of the effects device. Connect the output of the device to the appropriate Return Jack (Z or CC). High-quality shielded cables should be used for these connections. The following figures illustrate both types of monaural patch.

FIGURE 1

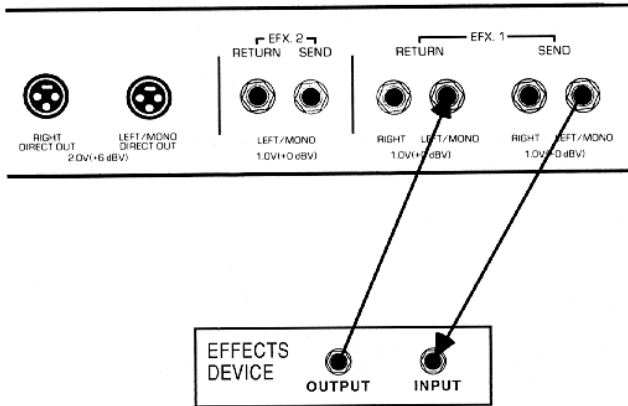


FIGURE 2

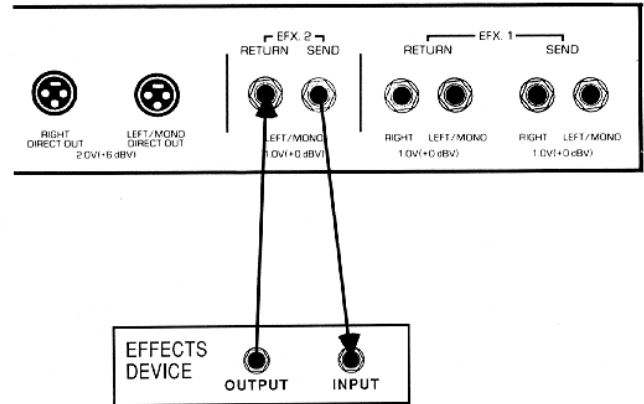


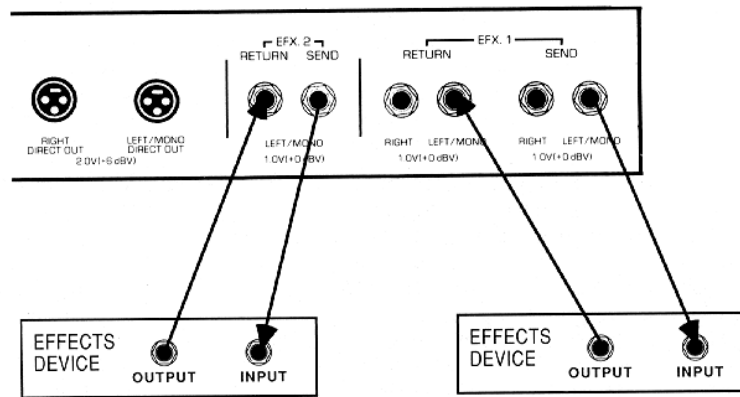
Figure 1 illustrates a pre-reverb patch, in which the signal is processed by the external device prior to entry into the internal reverb system. This patch requires that Effects Loop 1 be enabled via the EFX 1 Key (S) on the front panel.

Figure 2 illustrates a post-reverb patch, in which the signal passes through the internal reverb system prior to processing by the external device. This patch requires that Effects Loop 2 be enabled via the EFX 2 Key (T) on the front panel.

Both of these patches are of the simplest series-processing types, since in each case the external device is patched in series with the internal reverb system.

Monaural multistage series effects processing is possible by simultaneous use of Effects Loop 1 and Effects Loop 2. An example of this configuration is shown in Figure 3.

FIGURE 3



Selection of the effects device to be used in each loop is best determined by experimentation, although the general rule is that distortion or compression devices are used ahead of time modulation devices.

**Stereo Effects Processing**

The stereo processing capability of the PGP 20 allows a number of useful configurations. Again, discussion will begin with simple patches.

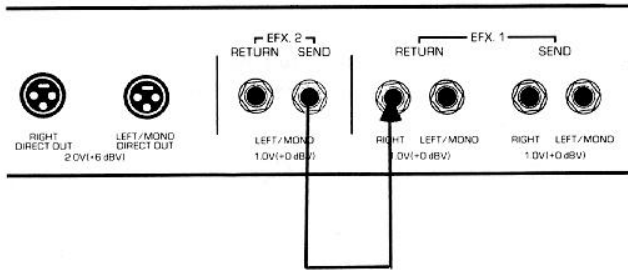
**Stereo Processing Using the Internal Reverberation System**

The PGP 20 incorporates an internal reverb system which is always available to process signals in the left/mono channel. Unless cross-channel interconnections are made, signals in the right channel cannot be reverb-processed. The PGP 20 is therefore capable of stereo-processed operation at all times, and will deliver both reverb-processed and "dry" signals simultaneously.

A simple patch allows stereo signal output in which signals in both channels are processed by the internal reverb system. To establish this patch, simply interconnect the Effects 2 Send Jack (BB) to the Effects 1 Right Return Jack (AA) by means of a shielded cable, as shown in figure 4. This configuration allows the levels of both reverb-processed signals to be mixed via the Post Gain Controls (E, F).

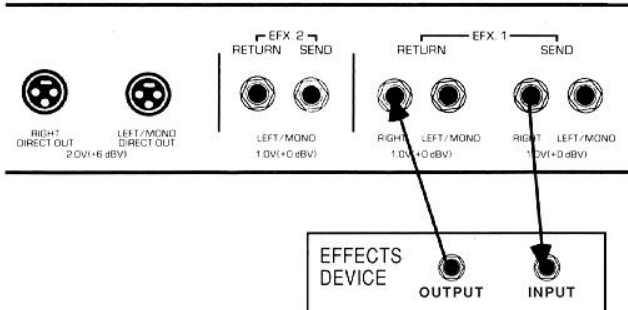


**FIGURE 4**



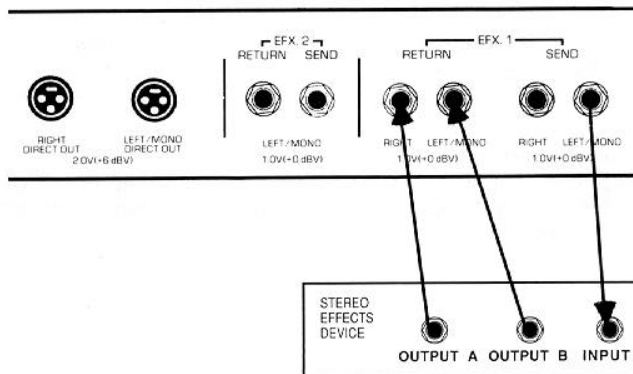
Another simple stereo effects patch may be established by inserting an external device between the Right Effects 1 Send Jack (Y) and the Right Effects 1 Return Jack (AA). In this configuration, signals in the left channel may be processed by the internal reverb system, while signals in the right channel are processed by the external device. An example of this patch is shown in Figure 5.

**FIGURE 5**



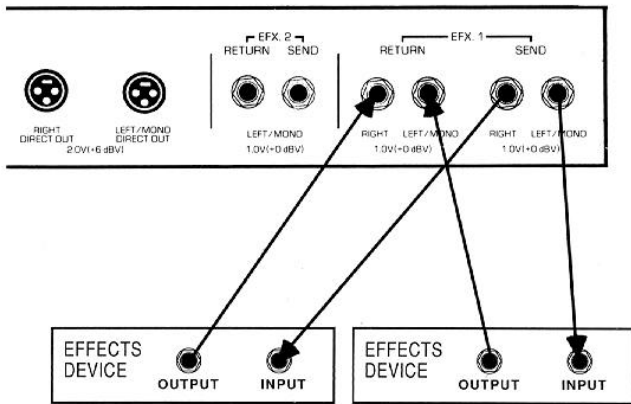
Since many available effects processors offer some form of dual-channel capability, utilization of such devices is greatly simplified with the PGP 20. A mono-input stereo-output device may be connected to the PGP 20 as shown in Figure 6. In this example, signals are sent to the external device from the Left/Mono Effects Send Jack (X) and are returned through both effects 1 Return Jacks (Z, AA).

**FIGURE 6**

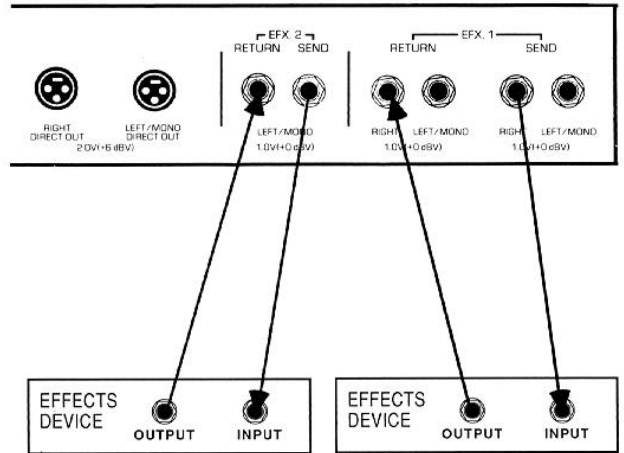


More complex stereo patches may be established by inserting external devices into both the left and right channels. Insertion into the right channel can only be accomplished at the Effects Right Send and Return jacks (Y, AA) within Effects Loop 1, while insertion into the left channel may be accomplished within either effects loop as previously described. Examples of both patches are shown in Figures 7 and 8.

**FIGURE 7**



**FIGURE 8**



Further processing within these configurations may be accomplished by insertion of additional devices within either effects loop. However, complete utilization of such a configurations will require external switching of the effects devices if their independent use is desired.

**Downstream Effects Processing**

Additional effects processing may always be accomplished by the interconnection of devices between the outputs of the PGP 20 and the inputs of other downstream system components. However, due to the high output potential of the PGP 20 (2 VRMS, +6 dBV), care should be taken to ensure that any downstream devices are capable of accepting such signal levels, and that the input level controls of such devices are carefully adjusted to prevent system overload.

## **SPECIFICATIONS**

**Nominal Levels are with Pre-Gain @ 5**  
**Minimum Levels are with Pre-Gain @ 10**

### **High Gain Input**

Impedance: High Z, 230K ohms  
Nominal Input Level: -28 dBV, 40mV RMS  
Minimum Input Level: -46 dBV, 5mV RMS  
Maximum Input Level: +4 dBV, 1.5V RMS

### **Low Gain Input:**

Impedance: High Z, 42K ohms  
Nominal Input Level: -22dBV, 80mV RMS  
Minimum Input Level: -40dBV, 10mV RMS  
Maximum Input Level: +10dBV, 3 V RMS

### **Equalization:**

Low, Mid, Shift, & High: Passive Type EQ  
Bright: +6dB @ 2KHz  
Active Presence EQ  
Thick

### **Effects 1 Patch Input/Output:**

Function: High Level Post EQ, Pre Reverb  
(Left/Mono Channel), Left and Right, Send  
and Return  
Load Impedance: 1K ohms or greater  
Nominal Output Level: +0dBV, 1 V RMS  
Input Impedance: High Z, 20K ohms or greater  
Input Level: 0 dBV, 1V RMS  
(Switching jacks provide patch output to patch  
input connection when not used.)

### **Effect 2 Patch Input/Output:**

Function: High Level Post EQ, Post Reverb  
(Left/Mono Channel) Mono Send and Return  
Load Impedance: 1 K ohms or greater  
Nominal Output Level: 0dBV, 1 V RMS  
Input Impedance: High Z, 20 K ohms minimum  
Input Level: 0 dBV, 1 V RMS

### **Equalized Direct Outputs:**

Function: Frequency compensated balanced  
outputs for direct connection to mixing console  
input.  
Left/Mono Channel: Load Impedance: 1 K ohms  
or greater  
Nominal Output Level: +6dBV, 2V RMS  
Right Channel: Load Impedance: 1 K ohms or  
greater  
Nominal Output Level: +6dBV, 2V RMS

### **Main Outputs:**

Function: Uncompensated, unbalanced outputs  
for connection to Power Amp(s).

### **Left/Mono Channel:**

Load Impedance: 1 K ohms or greater  
Nominal Output Level: +6dBV, 2 V RMS

### **Right Channel:**

Load Impedance: 1 K ohms or greater  
Nominal Output Level: +6dBV, 2 V RMS

### **External Control:**

MIDI In/Thru for complete selection of Program  
Presets.

**DANGER**

EXPOSURE TO EXTREMELY HIGH NOISE LEVELS MAY CAUSE A PERMANENT HEARING LOSS. INDIVIDUALS VARY CONSIDERABLY IN SUSCEPTIBILITY TO NOISE INDUCED HEARING LOSS, BUT NEARLY EVERYONE WILL LOSE SOME HEARING IF EXPOSED TO SUFFICIENTLY INTENSE NOISE FOR A SUFFICIENT TIME. THE U.S. GOVERNMENT'S OCCUPATIONAL SAFETY AND HEALTH ADMINISTRATION (OSHA) HAS SPECIFIED THE FOLLOWING PERMISSIBLE NOISE LEVEL EXPOSURES

DURATION PER DAY IN HOURS	SOUND LEVEL dBA, SLOW RESPONSE
8	90
6	92
4	95
3	97
2	100
1½	102
1	105
¾	110
½ or less	115

ACCORDING TO OSHA, ANY EXPOSURE IN EXCESS OF THE ABOVE PERMISSIBLE LIMITS COULD RESULT IN SOME HEARING LOSS. EAR PLUGS OR PROTECTORS IN THE EAR CANALS OR OVER THE EARS MUST BE WORN WHEN OPERATING THIS AMPLIFICATION SYSTEM IN ORDER TO PREVENT A PERMANENT HEARING LOSS IF EXPOSURE IS IN EXCESS OF THE LIMITS AS SET FORTH ABOVE. TO INSURE AGAINST POTENTIALLY DANGEROUS EXPOSURE TO HIGH SOUND PRESSURE LEVELS, IT IS RECOMMENDED THAT ALL PERSONS EXPOSED TO EQUIPMENT CAPABLE OF PRODUCING HIGH SOUND PRESSURE LEVELS SUCH AS THIS AMPLIFICATION SYSTEM BE PROTECTED BY HEARING PROTECTORS WHILE THE UNIT IS IN OPERATION.

**CAUTION**

THIS AMPLIFIER HAS BEEN DESIGNED AND CONSTRUCTED TO PROVIDE ADEQUATE POWER RESERVE FOR PLAYING MODERN MUSIC WHICH MAY REQUIRE OCCASIONAL PEAK POWER TO HANDLE OCCASIONAL PEAK POWER. ADEQUATE POWER 'HEADROOM' HAS BEEN DESIGNED INTO THIS SYSTEM. EXTENDED OPERATION AT ABSOLUTE MAXIMUM POWER LEVELS IS NOT RECOMMENDED SINCE THIS COULD DAMAGE THE ASSOCIATED LOUDSPEAKER SYSTEM. PLEASE BE AWARE THAT **MAXIMUM POWER** CAN BE OBTAINED WITH VERY LOW SETTINGS OF THE **GAIN** CONTROLS IF THE INPUT SIGNAL IS VERY STRONG.

1. Read all safety and operating instructions before using this product.
2. All safety and operating instructions should be retained for future reference.
3. Obey all cautions in the operating instructions and on the back of the unit.
4. All operating instructions should be followed.
5. This product should not be used near water, i.e. a bathtub, sink, swimming pool, wet basement, etc.
6. This product should be located so that its position does not interfere with its proper ventilation. It should not be placed flat against a wall or placed in a built-in enclosure that will impede the flow of cooling air.
7. This product should not be placed near a source of heat such as a stove, radiator or another heat producing amplifier.
8. Connect only to a power supply of the type marked on the unit adjacent to the power supply cord.
9. Never break off the ground pin on the power supply cord. For more information on grounding write for our free booklet "Shock Hazard and Grounding."
10. Power supply cords should always be handled carefully. Never walk or place equipment on power supply cords. Periodically check cords for cuts or signs of stress, especially at the plug and the point where the cord exits the unit.
11. The power supply cord should be unplugged when the unit is to be unused for long periods of time.
12. If this product is to be mounted in an equipment rack, rear support should be provided.
13. Metal parts can be cleaned with a damp rag. The vinyl covering used on some units can be cleaned with a damp rag or an ammonia based household cleaner if necessary.
14. Care should be taken so that objects do not fall and liquids are not spilled into the unit through the ventilation holes or any other openings.
15. This unit should be checked by a qualified service technician if:
  - A. The power supply cord or plug has been damaged.
  - B. Anything has fallen or been spilled into the unit.
  - C. The unit does not operate correctly.
  - D. The unit has been dropped or the enclosure damaged.
16. The user should not attempt to service this equipment. All service work should be done by a qualified service technician.

